

BOOST YOUR DEVELOPMENT!

Our experts powered by innovation, and our multiple registered patents will support all your R&D projects.

INNOVATION  - SUCCESS  - TRUST 

$$\begin{aligned}
 \mu s &= \sum_f (\Psi_f (i\gamma^\mu \partial_\mu - m_f) \Psi_f - c_{Q_f} \Psi_f \gamma^\mu \Psi_f A_\mu) + \\
 &\gamma^\mu b_L W_\mu^+ + \bar{b}_L \gamma^\mu a_L W_\mu^- + \frac{g}{2c_w} \sum_f \Psi_f \gamma^\mu (I_f^3 - 2s_w^2 Q_f - I_f) \\
 &- \partial_\nu A_\mu - ie(W_\mu^- W_\nu^+ - W_\mu^+ W_\nu^-) - \frac{1}{2} |\partial_\mu W_\nu^+ - \partial_\nu W_\mu^+ \\
 &+ ie(W_\mu^+ A_\nu - W_\nu^+ A_\mu) + ig' c_w (W_\mu^+ Z_\nu - W_\nu^+ Z_\mu)^2 + \\
 &+ \frac{1}{4} |\partial_\mu Z_\nu - \partial_\nu Z_\mu + ig' c_w (W_\mu^- W_\nu^+ - W_\mu^+ W_\nu^-)|^2 + \\
 &\frac{f_2^2 \eta^2}{2} - \frac{g M_\eta^2}{8 M_\eta \eta^2} - \frac{g^2 M_\eta^2}{32 M_\eta^2 \eta^4} + |M_W W_\mu^+ + \frac{g}{2} \eta W_\mu^+|^2 + \\
 &\frac{1}{2} |\partial_\mu \eta + i M_2 Z_\mu + \frac{ig}{2c_w} \eta Z_\mu|^2 - \sum_f \frac{g}{2 M_W} \Psi_f \Psi_f \eta
 \end{aligned}$$

Applied Research

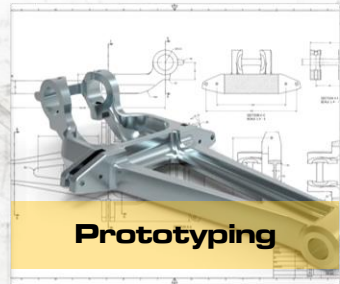
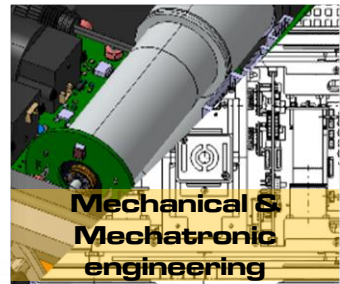
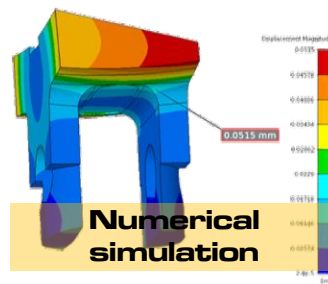
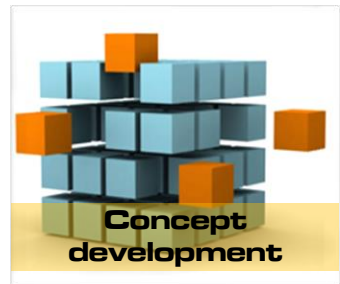

M-Tecks EAC is approved Research Tax Credit and Innovation Tax Credit by the General Directorate for Research and Innovation.

M-Tecks EAC
 Engineering
 Assembly
 Company

ZA de l'Esoudier
 19270 DONZENAC

Tel. : +335-55-24-22-86
 Fax : 05-55-24-21-59
 e-mail : contact@M-TecksEAC.com

www.M-TecksEAC.com



More details on our website:
www.M-TecksEAC.com



Mechanical and mechatronic engineering (research in robotics, innovative process and products, technical calculations, process design)

Mechanical and mechatronic engineering (research in robotics, R&D process and innovative products, sizing calculations, design of production means, subcontracting and manufacturing management, manufacturing and assembly)

EXAMPLES OF ACHIEVEMENTS

↳ Portable equipment

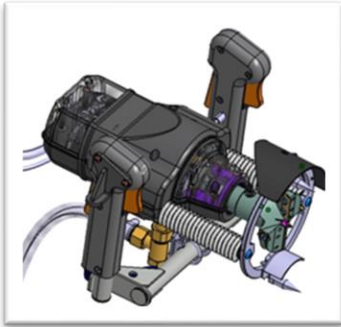

- Mechanical solution determination with peristaltic pump
- Power electronics development
- Portable HMI development
- Prototype experimental qualification

► Industry



↳ Instrumented accessory



- Concept proposition
- Mechanical development
- Simulation EF in fatigue
- PCB and software development
- Algorithm optimization
- Prototype qualification
- Industrialization

► Aeronautics



↳ High resolution shutter

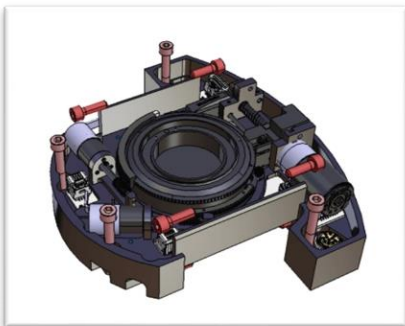

- Mechanical and electronic development
- EF Simulation of vibratory and thermal phenomena
- PCB definition integrated into the mechanical structure
- Test bench development and qualification tests
- Industrialization

► Aeronautics



↳ Calibration equipment

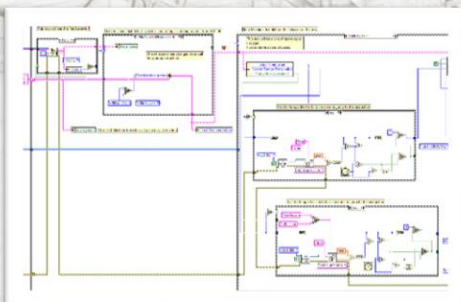

- Code development under LABVIEW
- 3 layers of code: test bench control, equipment simulator, driver management
- Test bench integration and qualification

► Industry



► Defence

